



- TASTE THE DIFFERENCE -

MODEL 876

This floor-model frozen beverage freezer is designed to serve high quality fast, easy, portion-controlled, labor-saving slush and smoothies. Syrup racking with 5 bottles provides flavor options while running a neutral or core base flavor. Great for youth baseball venues, ice cream stores, fun parks and more.

MODEL 876C

This counter-model frozen beverage freezer is designed to serve high quality fast, easy, portion-controlled, labor-saving slush and smoothies. Run a neutral or core flavor and increase your flavor options with the 6 syrup bottles provided in the rack. Perfect for country clubs, pools, festival booths and medium size hot dog and hamburger stands that have counter space available to add fun and profitable menu items.

The Electro Freeze Advantage

- **Product Consistency Control** provides a smooth frozen product with tiny uniform ice crystals.
- **Minimal Maintenance**, simple to operate and easy to clean.
- **Built for long life** and dependability.
- **Add to Your Profits** with the sale of frozen beverages producing large profit margins.
- **Experience Tells** Electro Freeze has been manufacturing quality frozen treat machines since 1929. Superior engineering, product innovations, sturdy construction, quality craftsmanship and dependable performance are Electro Freeze hallmarks.
- **Superior Service Support** backed by a worldwide distributor network.

SLUSH AND FROZEN BEVERAGE FREEZERS

MODEL 876



MODEL 876C



876 & 876C Slush Freezers



MODEL 876

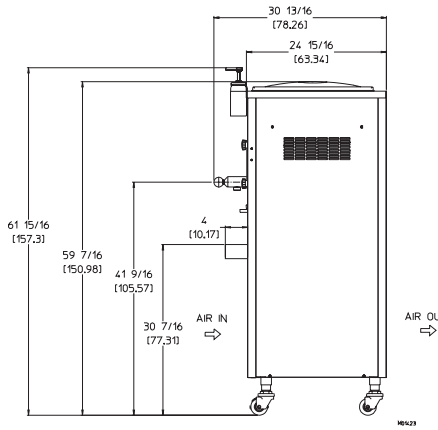
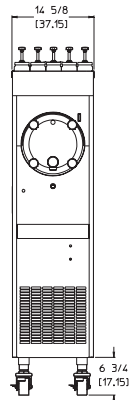

MODEL 876C

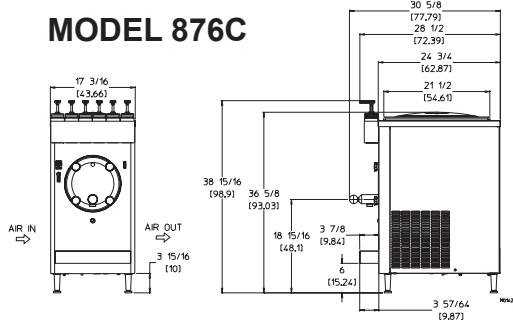

MODEL 876 & 876C SPECIFICATIONS

Due to continual product improvements all specifications are subject to change without notice.

Weights	876		876C	
	lbs.	kgs.	lbs.	kgs.
Net	280	127	255	116
Crated	355	152	274	124
	cu.ft.	cu.m.	cu.ft.	cu.m.
Volume	30.08	0.85	20.53	0.58
Dimensions	in.	cm	in.	cm
Width	14-5/8	37.15	17-3/16	43.66
Depth	24-15/16	63.34	24-3/4	62.87
Height	59-7/16	150.98	36-5/8	93.03

Electrical	Minimum Wire Ampacity	Maximum Breaker/Fuse Size	NEMA Plug Type
115/60/1 Air	20A	20A	5-20P
	Total Amps (Qty)	kW	Poles (P) Wires (W)
115/1/50 Air	7.1	1.2	2P, 2W

Electrical characteristics other than above available on request from factory or local distributor. Check nameplate for exact electrical data.

Bidding Spec

Electrical: Volt _____ Hz _____ Ph _____

Cooling: _____ Neutral _____ Yes _____ No

Options: _____

Electrical

One dedicated electrical connection is required. Connects to a standard NEMA 5-20R receptacle. See electrical chart for the proper requirement. Consult your local electrical codes for cord and receptacle specifications.

Beater Motor

One, 1/4 hp.

Refrigeration Systems

One, 5000 Btuh. R404a. Models 876 and 876C Btuh may vary depending on compressor used.

Air Cooled

3" (7.62 cm) air space required on both sides and the rear panel for proper air circulation.

Mix Hopper Capacity: 20 quarts (18.93 liters) Freezing Cylinder

Capacity: 14.6 quart (13.8 liters) Models 876, 876C

Certified and/or listed by:



*UL listed and listed by Underwriters Laboratories under Canadian National Standard C22.2 No. 120-13

**Selected voltages only. Contact H.C. Duke to verify agency needs.

Electro Freeze div. of H.C. Duke & Son, LLC

2116-8th Avenue, East Moline, Illinois
61244 USA

Phone : (800) 922 2629

E-mail: Sales@ElectroFreezeOfNewEngland.com

www.ElectroFreezeOfNewEngland.com