



- TASTE THE DIFFERENCE -

### MODEL B12V

This large-capacity batch freezer produces the highest quality ice cream, gelato, sorbet, Italian ice or sherbets. Mechanically simple and exceptionally dependable, this machine is perfect for gelato, custard and water ice shops.

### MODEL B24V

This high-capacity batch freezer is simple and efficient, making it perfect for gelato, custard and water ice shops.. Make large volumes of your own signature Gelato, Italian Ice, Sorbets and high or low overrun ice cream.

### The Electro Freeze Advantage

- **Cam Door latch** provides quick interior access
- **Exclusive Auger Design** gently blends, reducing agitation and maintains product quality and consistency.
- **Auger and Dispensing Head Design** provides excellent product extraction and less flavor overlap.
- **Superior Product Quality** is an Electro Freeze trademark unmatched frozen product quality through simple and effective design
- **Built-in Faucet** with flex hose for fast and easy cleaning
- **Digital timer** with audible alarm
- **Optional Variable Speed Overrun & Viscosity Control** Allows for precise control of viscosity and overrun to maximize your profits. Produces a consistent finished product and automatic shut off when the batch reaches the desired consistency.
- **Extra Large Discharge Chute & Oversized Feed Hopper** allows for quicker dispensing of product for overrun consistency& easier loading of ingredients.
- **Experience Tells** Electro Freeze has been manufacturing quality frozen treat machines since 1929. Superior engineering, product innovations, sturdy construction, quality craftsmanship and dependable performance are Electro Freeze hallmarks.
- **Superior Service Support** backed by a worldwide distributor network.

## BATCH FREEZERS

### NEW EXTENDED WARRANTY

- 1 Year Parts\*
- 1 Year Labor
- 5 Year Compressor



\*Excludes normal wear parts, see warranty card for details.

# B12V & B24V Batch Freezers

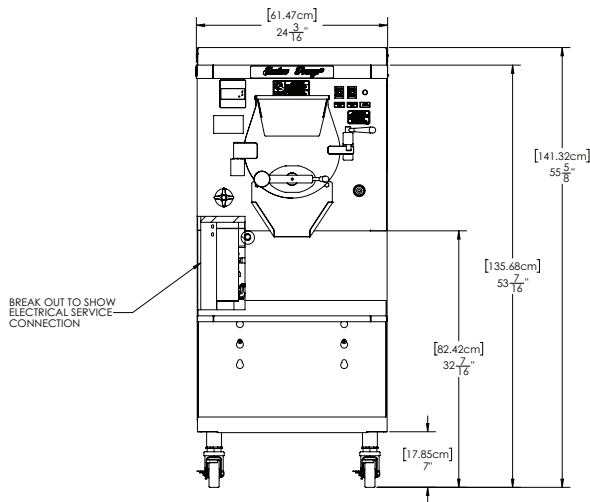

ALL CONNECTIONS ARE MADE THROUGH BOTTOM OF FREEZER

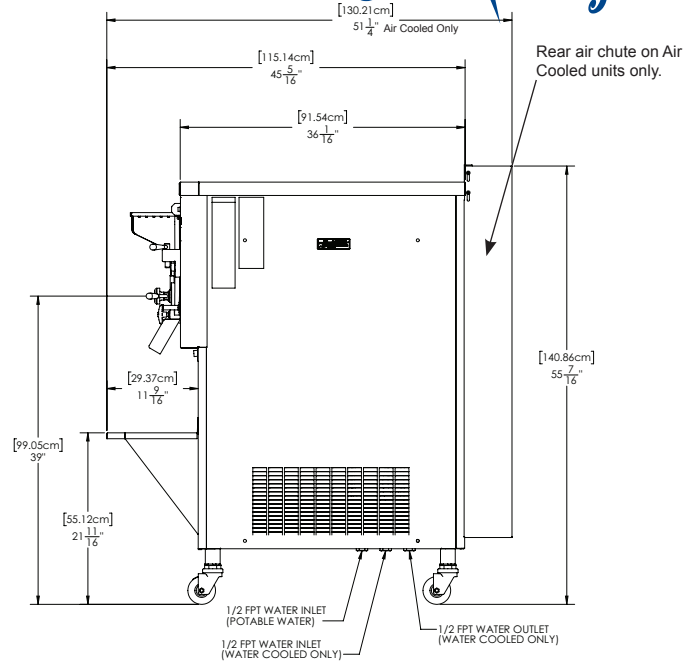

## MODEL B12V & B24V SPECIFICATIONS

Due to continual product improvements all specifications are subject to change without notice.

	B12V		B24V		
	lbs.	kgs.	lbs.	kgs.	
<b>Weights</b>					
Net	605	274	705	320	
Crated	695	315	795	360	
	<b>cu.ft.</b>	<b>cu.m.</b>	<b>cu.ft.</b>	<b>cu.m.</b>	
Volume	58.42	1.65	58.42	1.65	
<b>Dimensions</b>	<b>in.</b>	<b>cm</b>	<b>in.</b>	<b>cm</b>	
Width	24-3/16	61.44	24-3/16	61.44	
Depth-Air	42	106.68	42	106.68	
Depth-Water	36-1/16	61.60	36-1/16	61.60	
Height	53-3/8	135.54	53-3/8	135.54	
<b>Electrical</b>	<b>Maximum Fuse Size*</b>		<b>Minimum Circuit Ampacity*</b>		<b>Poles (P) Wires (W)</b>
	<b>B12V</b>	<b>B24V</b>	<b>B12V</b>	<b>B24V</b>	
208-230/60/1 Water	35	-	27.5	-	-
208-230/60/3 Water	20	40	16.0	28.0	3P, 3W
208-230/60/1 Air	40	-	29.0	-	-
208-230/60/3 Air	20	40	17.0	29.5	3P, 3W

Electrical characteristics other than above available on request from factory or local distributor. \*Check nameplate for exact electrical data.

### Bidding Spec

Electrical: Volt \_\_\_\_\_ Hz \_\_\_\_\_ Ph \_\_\_\_\_

Cooling: \_\_\_\_\_ Neutral \_\_\_\_\_ Yes \_\_\_\_\_ No \_\_\_\_\_

Options: \_\_\_\_\_



Made in the USA

Electro Freeze div. of H.C. Duke & Son, LLC

2116-8th Avenue, East Moline, Illinois 61244 USA

### Electrical

A dedicated electrical connection is required for both models. Manufactured to be permanently connected. See electrical chart for the proper requirement. Consult your local electrical codes for cord and receptacle specifications.

### Beater Motor

B12V, 3hp. (2.3kW)  
B24V, 5hp. (3.73kW)

### Refrigeration Systems

B12V, 2.5hp. (1.9kW) R404a.  
B24V, 3.5hp. (2.61kW) R404a.

### Air/Water Cooled

3" (7.6 cm) is required on both side panels for proper air circulation.

### Water Cooled

Water pressure between 35-140 psig (241-965 kPa) for proper operation.

### Freezing Cylinder Capacity:

B12V, 14 quarts (13.25 liters)  
B24V, 25 quarts (23.65 liters)

Phone : (800) 922 2629

E-mail: Sales@ElectroFreezeOfNewEngland.com

www.ElectroFreezeOfNewEngland.com