



- TASTE THE DIFFERENCE -

MODEL CS700

This counter-model shake freezer features a small footprint. Great for restaurants, QSRs, ice cream shops, self-serve college & university cafeterias, retirement villages and healthcare facilities.

The Electro Freeze Advantage

- **Exclusive Auger Design** gently blends, reducing agitation and maintaining product quality and consistency
- **Consistency control** designed to dispense the finest frozen product available
- **Air Filer** washable filter keeps the condenser clean
- **Compact Design with** small footprint
- **Experience Tells** Electro Freeze has been manufacturing quality frozen treat machines since 1929. Superior engineering, product innovations, sturdy construction, quality craftsmanship and dependable performance are Electro Freeze hallmarks.
- **Superior Service Support** backed by a worldwide distributor network

Optional

- **Front Mount Shake Mixer** (as shown)
- **Flavor Rack**
- **Splash guard** (as shown)
- **Top Air Discharge Chute** the top air discharge chute on air cooled models allows units to be set side by side and air flow to be diverted up.
- **Cabinet** an optional commercial grade stainless steel cabinet is available includes heavy duty casters, a sturdy latch and gives you 6 cubic feet of storage. (as shown)

GRAVITY SHAKE FREEZER COMPACT SERIES



Shown with Optional Mixer and Splash Shield



Shown with Optional Mixer and Cabinet

CS700 Shake Freezer

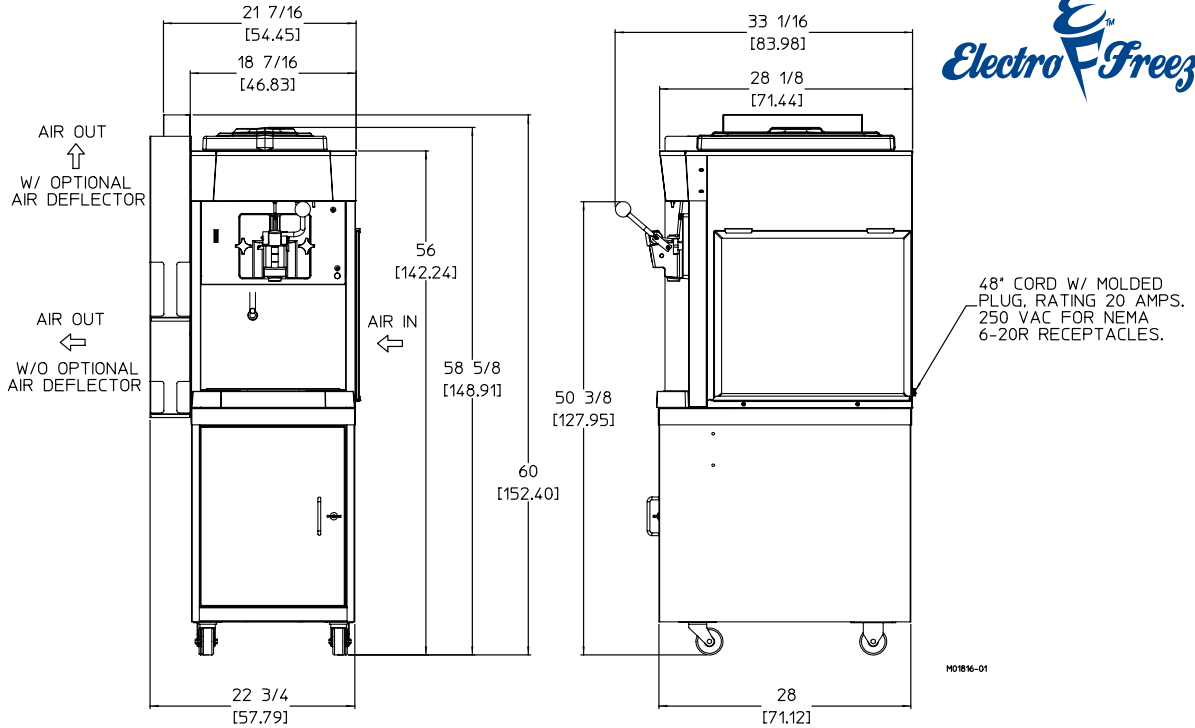

MODEL CS700 SPECIFICATIONS

Due to continual product improvements all specifications are subject to change without notice.

Weights	lbs.	kgs.	
Net	294	133.36	
Crated	390	176	
	cu.ft.	cu.m.	
Volume	39.47	1.12	
Dimensions	in.	cm	
Width	18-7/16	46.83	
Depth	28-1/8	71.44	
Height	35-1/4	89.54	
Electrical	Maximum Fuse Size	NEMA Plug Type	Poles (P) Wires (W)
208-230/60/1 Air	12.5	6-20P	2P, 2W
	Total Amps	kW	Poles (P) Wires (W)
220-240/50/1 Air	12	2.4	2P, 2W

Electrical characteristics other than above available on request from factory or local distributor. Check nameplate for exact electrical data.

Bidding Spec

Electrical: Volt _____ Hz _____ Ph _____

Cooling: _____ Neutral _____ Yes _____ No

Options: _____

Electrical

One dedicated electrical connection is required. Connects to a standard NEMA 6-20R receptacle. See electrical chart for the proper requirement. Consult your local electrical codes for receptacle specifications.

Beater Motor

One, 1/2 hp.

Refrigeration Systems

One, 8,000 Btuh. R404a.
Btuh may vary depending on compressor used.

Air Cooled

3" (7.6cm) air space required on both sides and the rear panel for proper air circulation.

Mix Hopper Capacity: one - 20 quarts (18.8 liters)

Freezing Cylinder Capacity: one - 7.6 quarts (7.1 liters)

Certified and/or listed by:



*UL listed and listed by Underwriters Laboratories under Canadian National Standard C22.2 No. 120-M91(R2008)

Electro Freeze div. of H.C. Duke & Son, LLC

2116-8th Avenue, East Moline, Illinois 61244 USA

Phone : (800) 922 2629

E-mail: Sales@ElectroFreezeOfNewEngland.com

www.ElectroFreezeOfNewEngland.com